

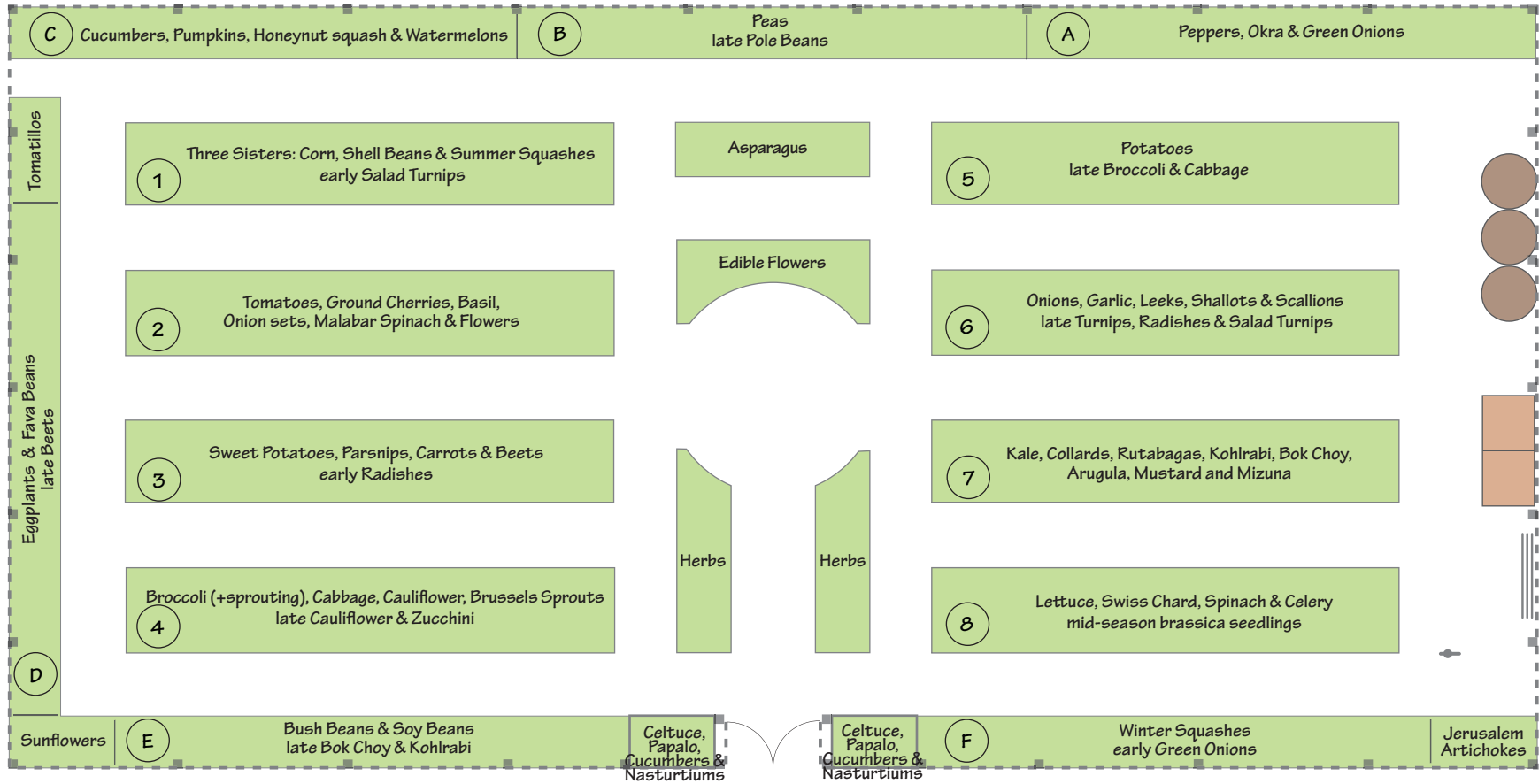

Annual crop rotations: 1 → 2 → 3 → 4 → 1... 5 → 6 → 7 → 8 → 5... A → B → C → D → E → F → A...



2026 PLANTING PLAN

ROBBINS FARM GARDEN

1/8" = 1'-0"

**THREE SISTERS BED: CORN, SHELL BEANS & SUMMER SQUASHES**

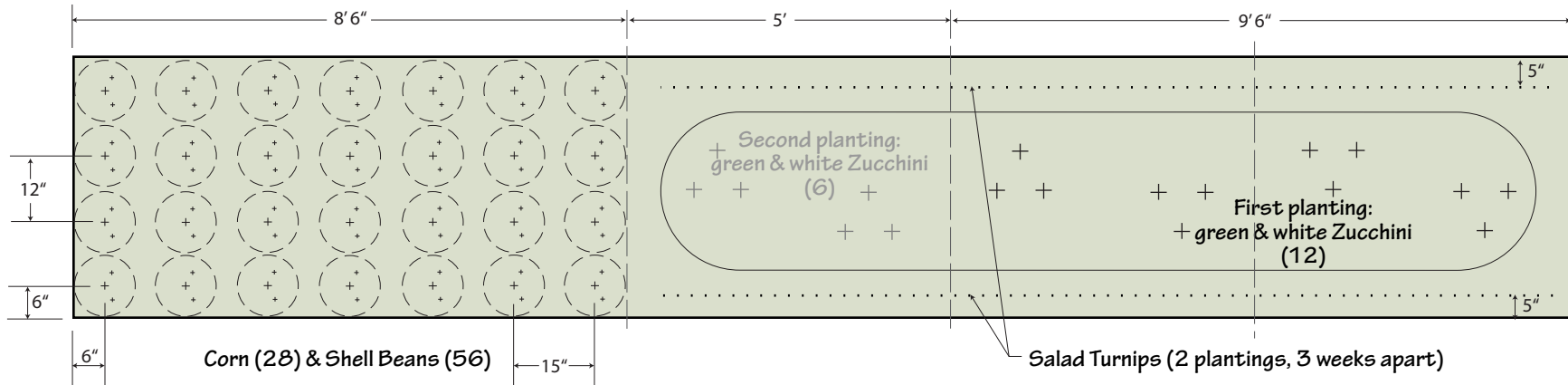

**TOMATO, BASIL & ONION SET BED**

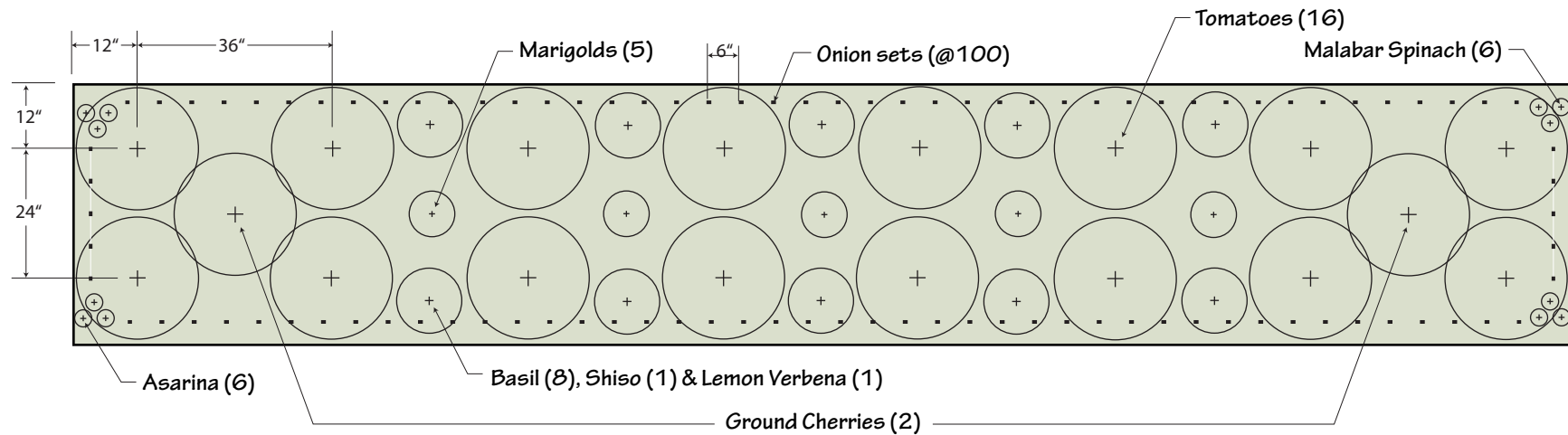

### SWEET POTATO, PARSNIP, CARROT & BEET BED

### Spring planting plan

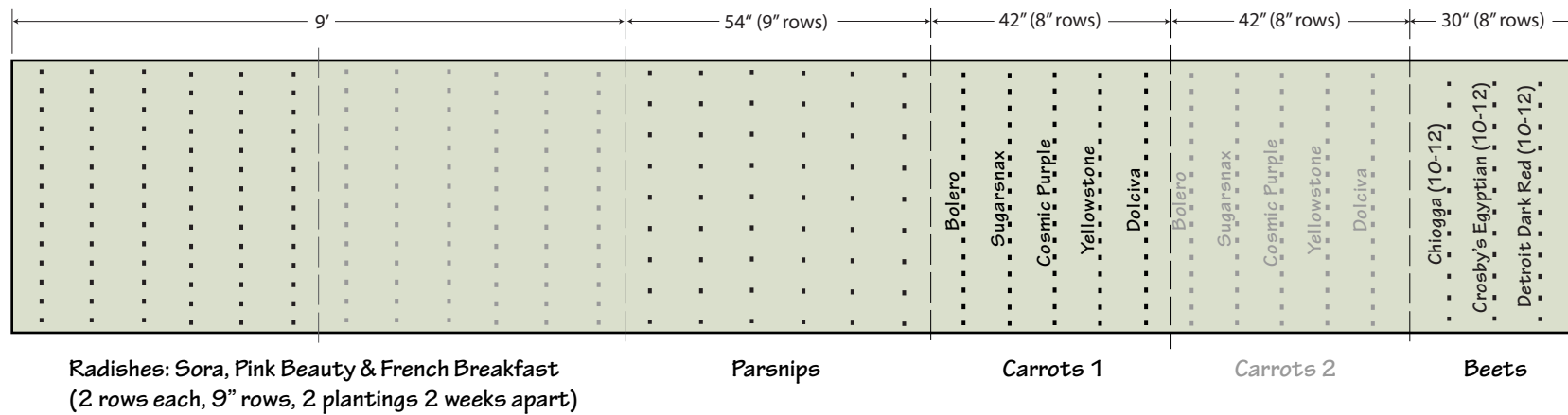

### Fall planting plan

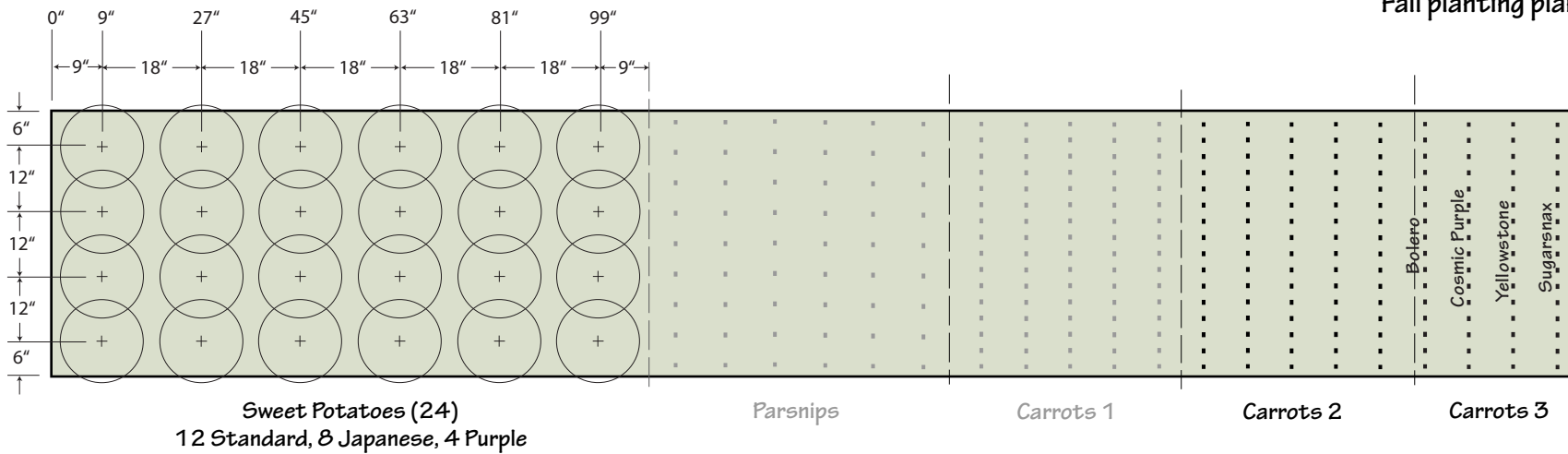

**BROCCOLI, CABBAGE, CAULIFLOWER & BRUSSELS SPROUTS BED**

**Spring planting plan**

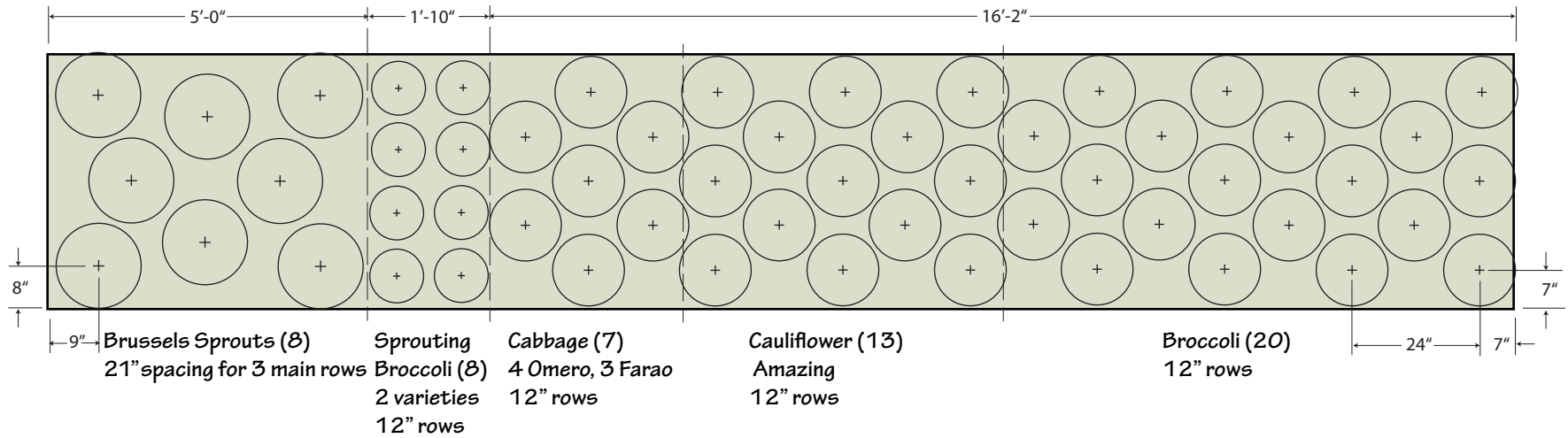

**Fall planting plan**

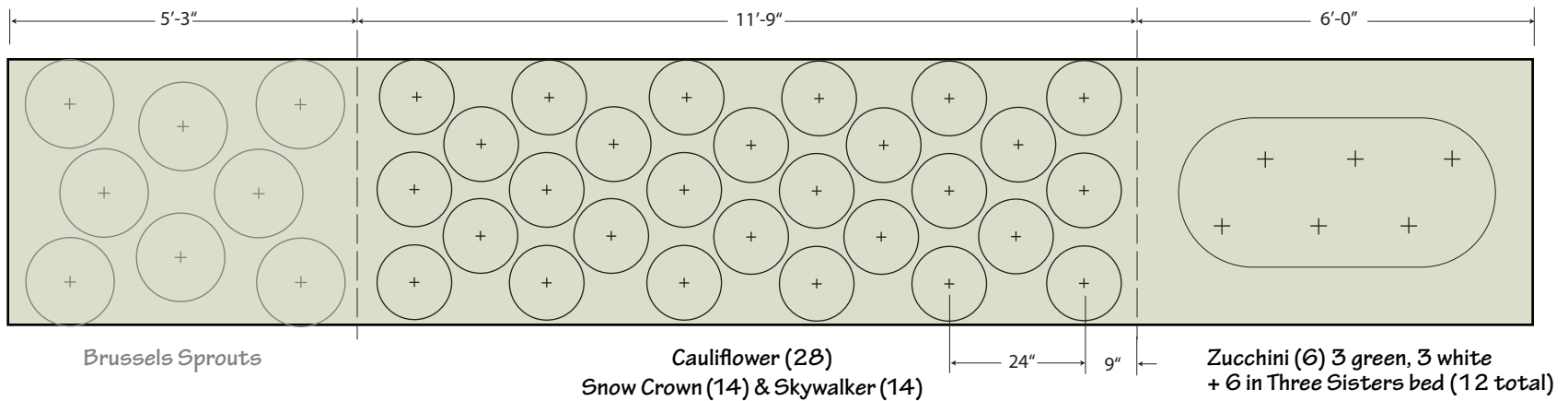

POTATO BED

Spring planting plan

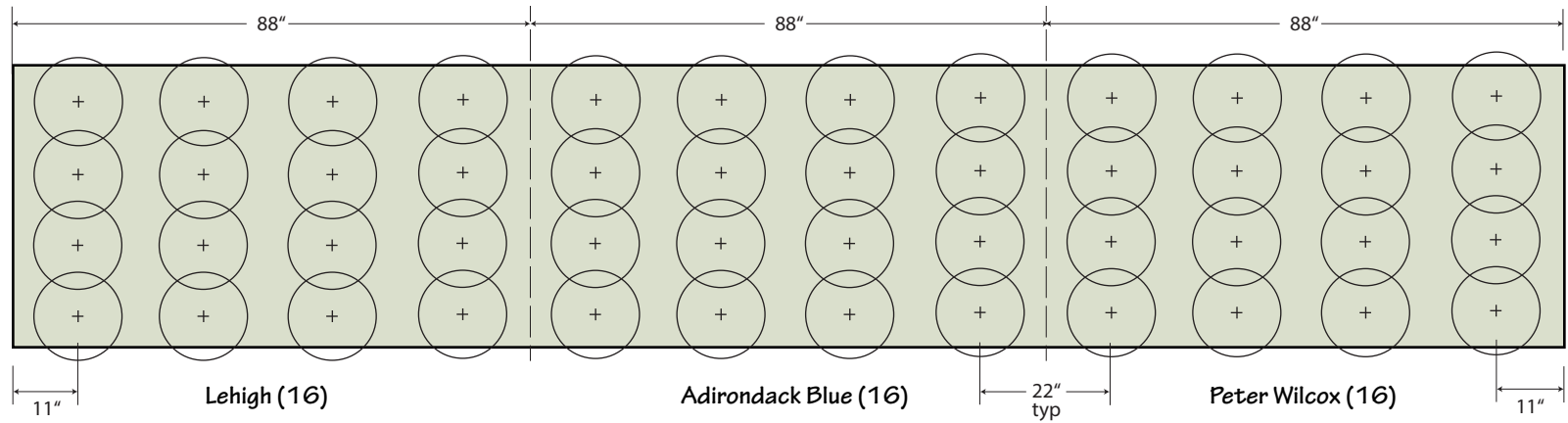

Fall planting plan

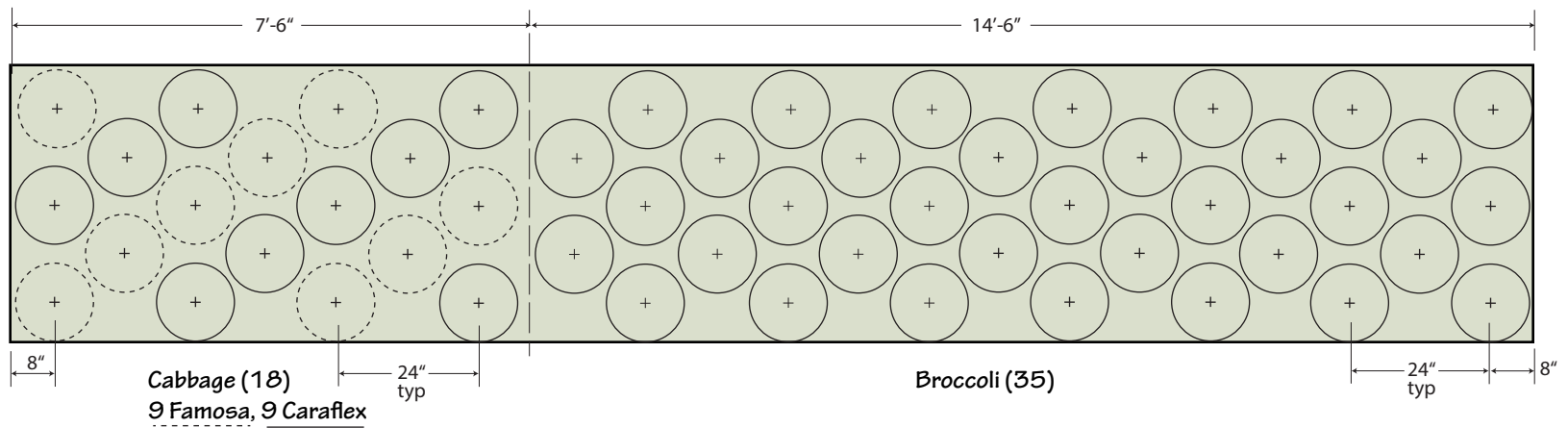

# ONIONS, GARLIC, LEEKS, SHALLOTS, SCALLIONS & CELERY

## Spring planting plan

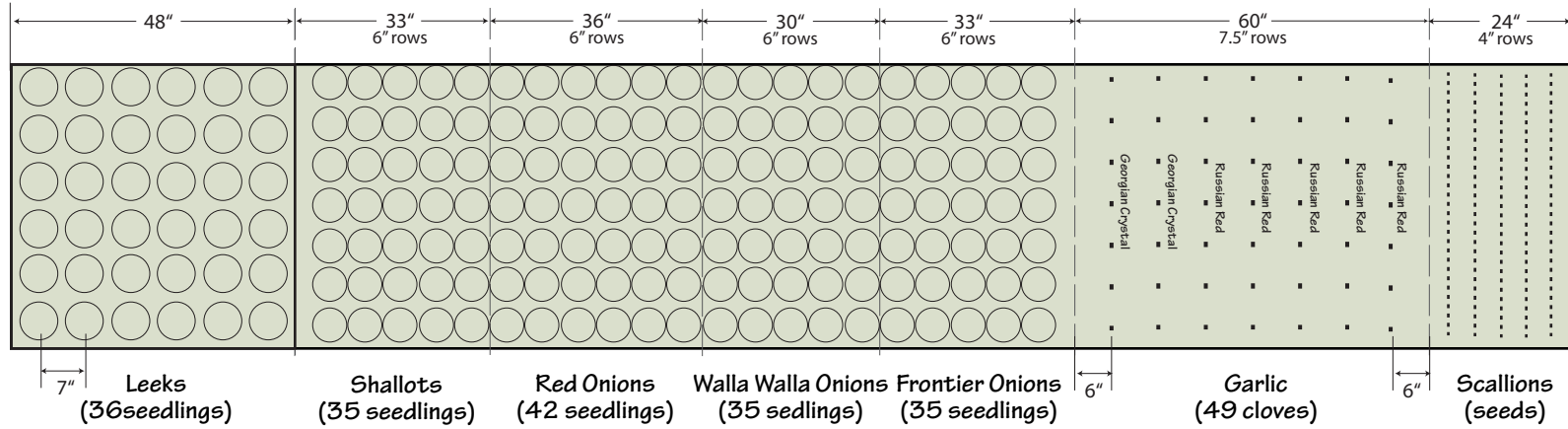

## Fall planting plan

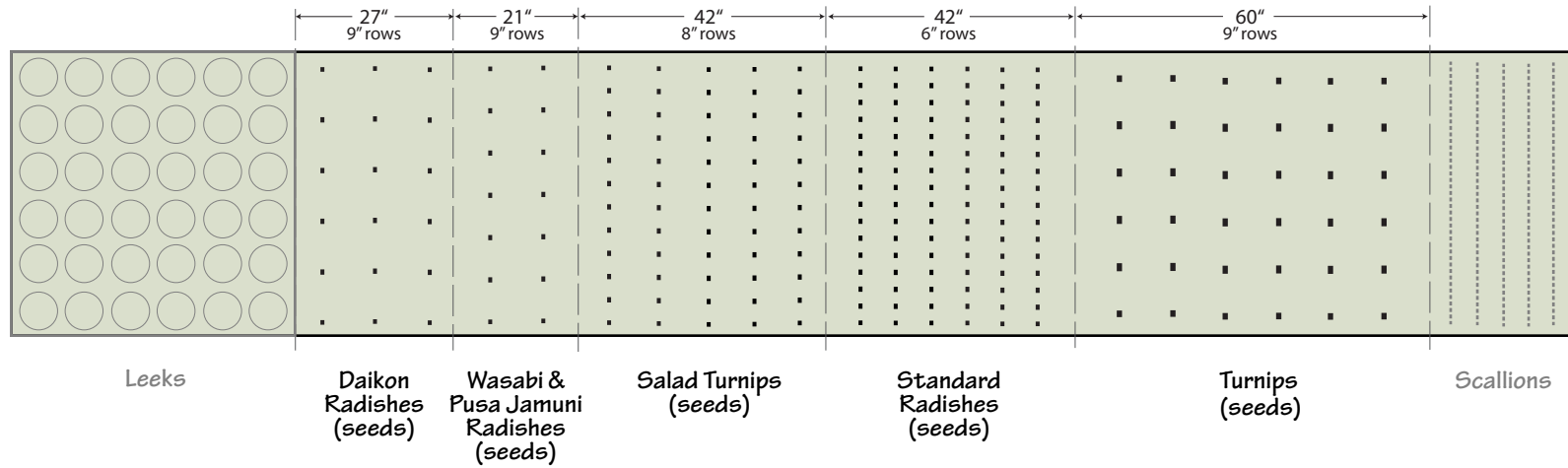

KALE, COLLARDS, RUTABAGAS, KOHLRABI, BOK CHOY, ARUGULA & MUSTARD

Spring planting plan

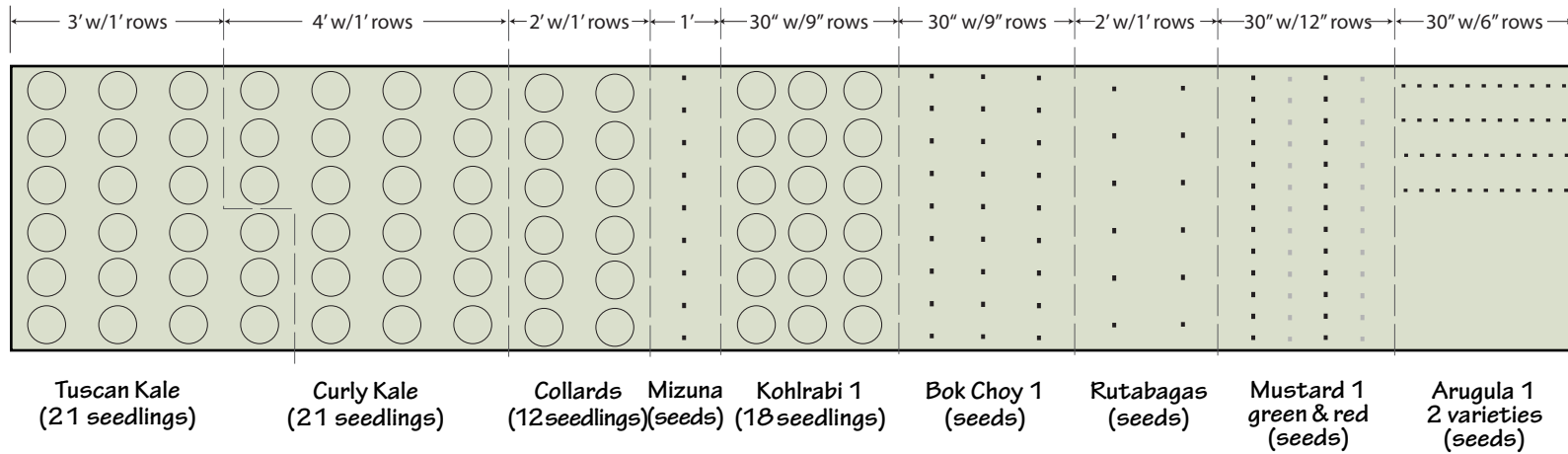

Summer planting plan

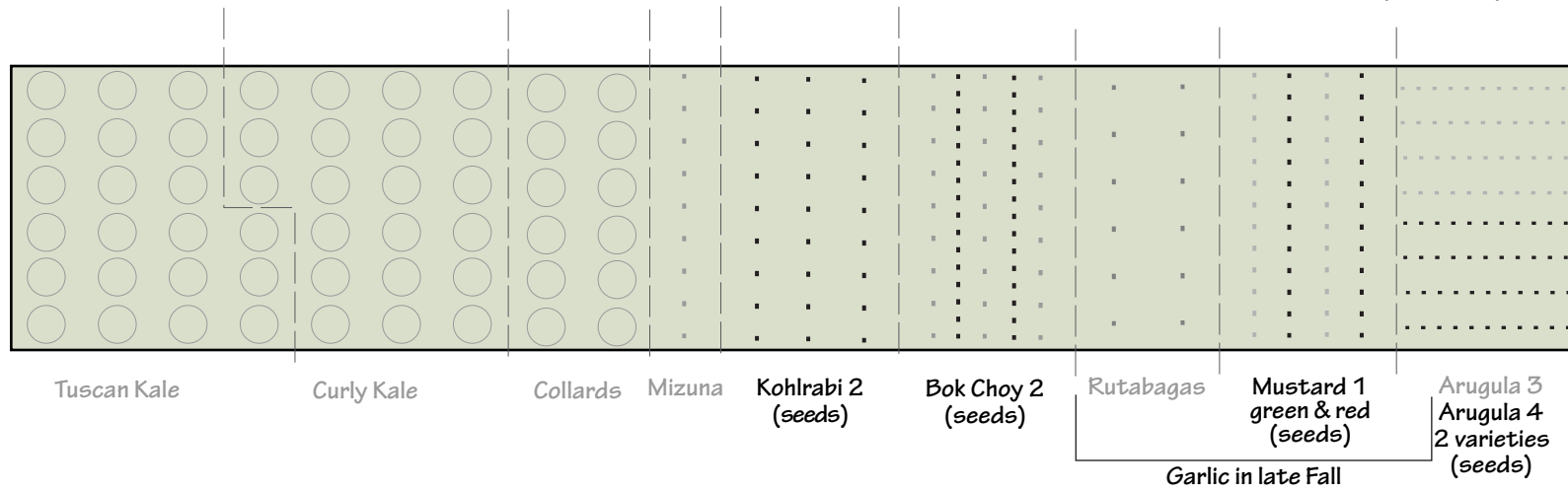

# LETTUCE, SWISS CHARD, PERPETUAL SPINACH & SPINACH

## Spring planting plan

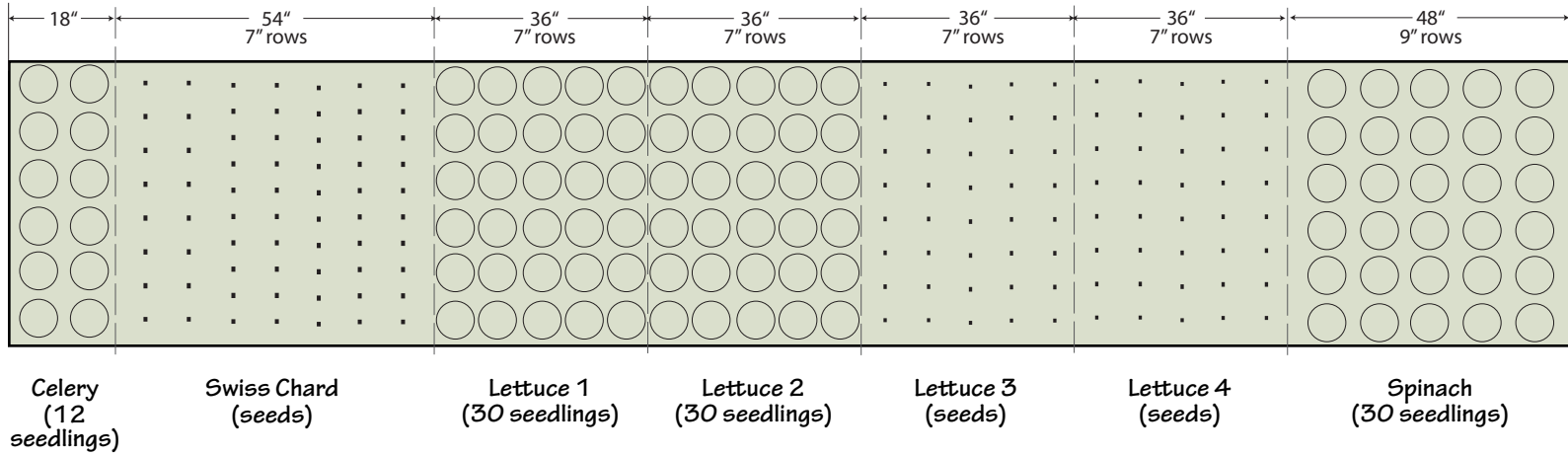

## Summer planting plan

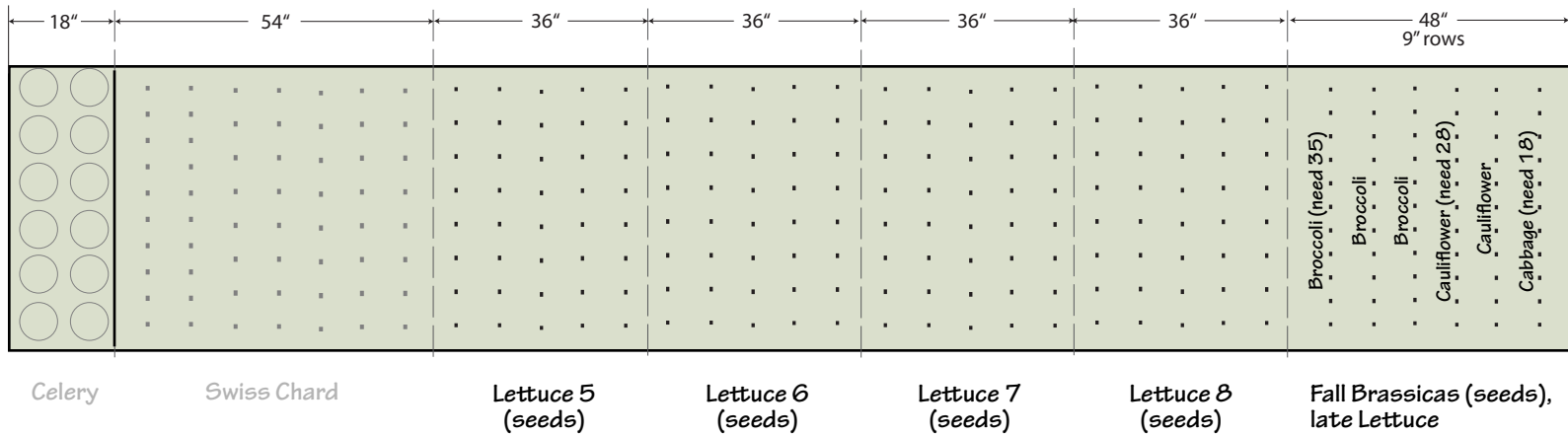

### PEAS & LATE POLE BEANS BED

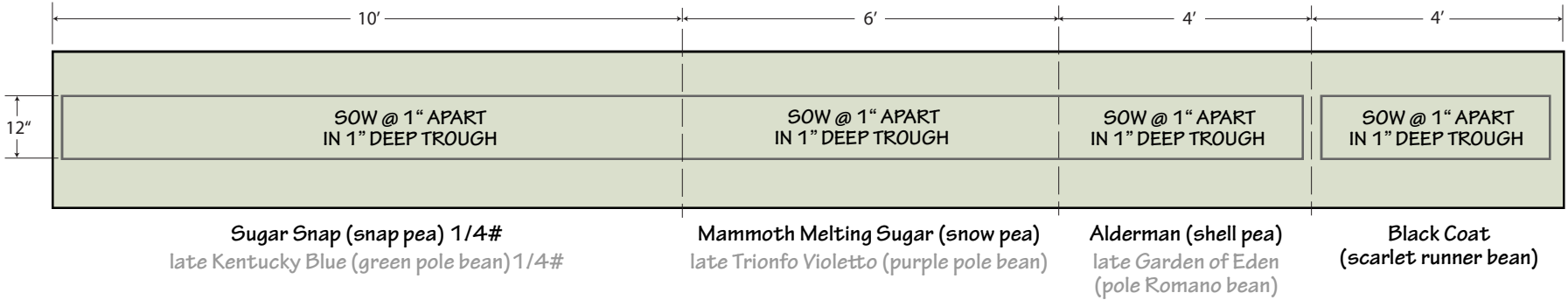

### PEPPER & OKRA BED

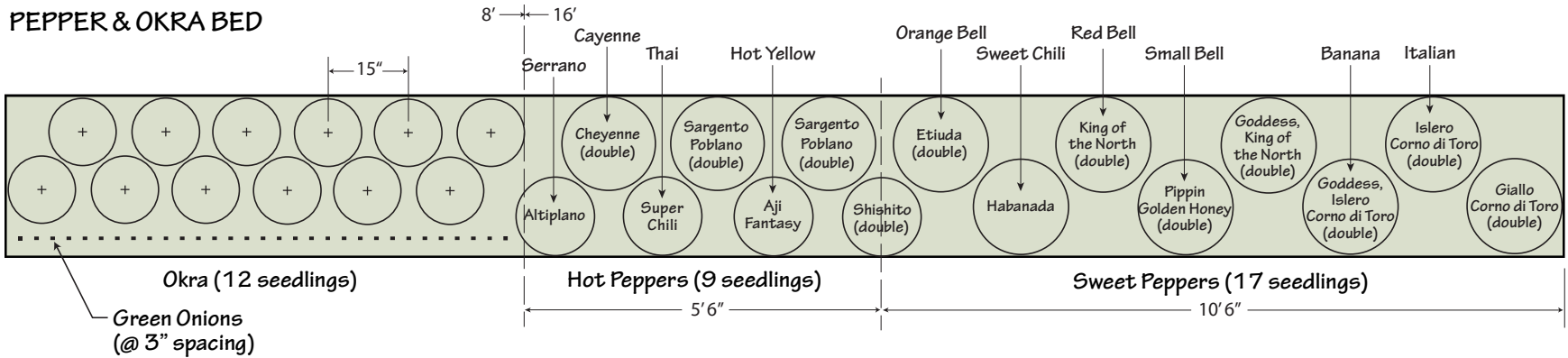

### CUCUMBER, PUMPKIN, HONEYNUT & WATERMELON BED

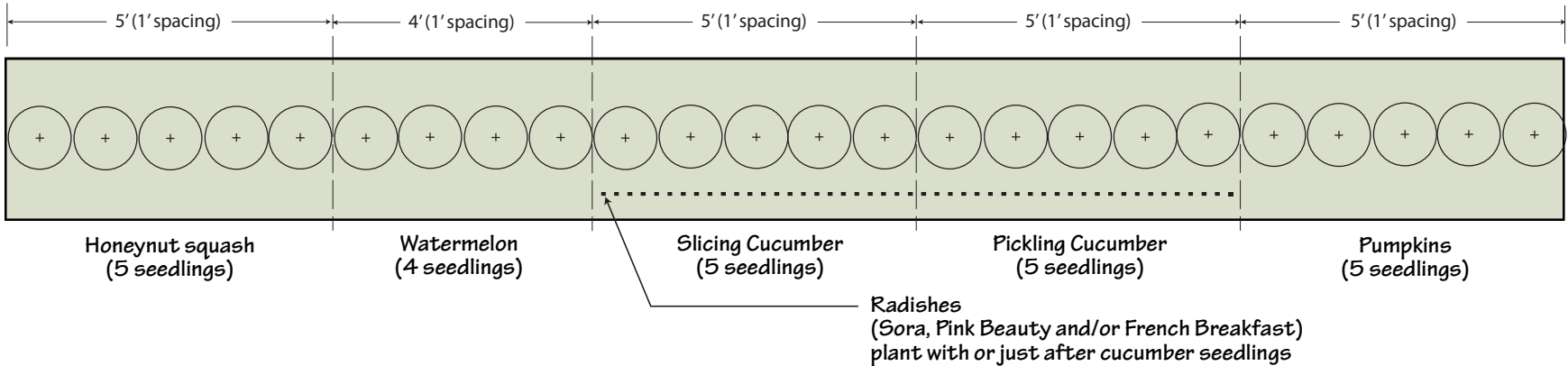

### BUSH BEAN & SOYBEAN BED

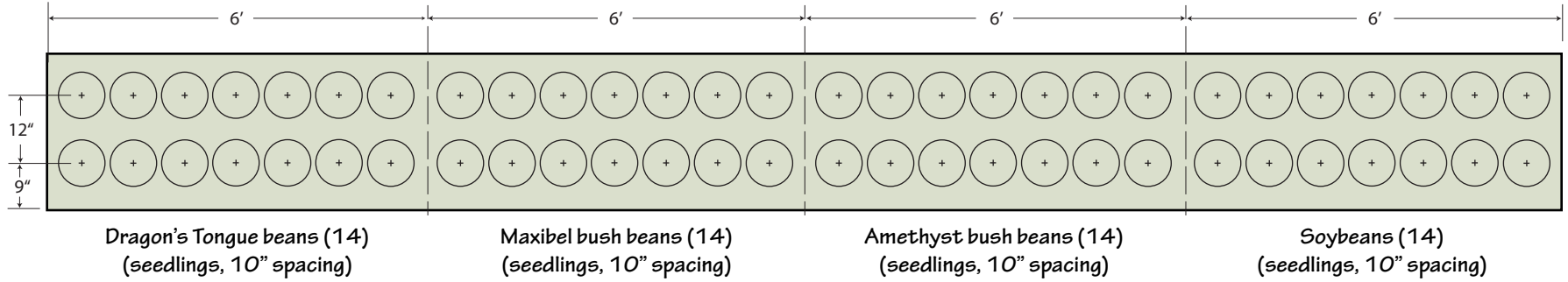

### EGGPLANT & FAVA BEAN BED

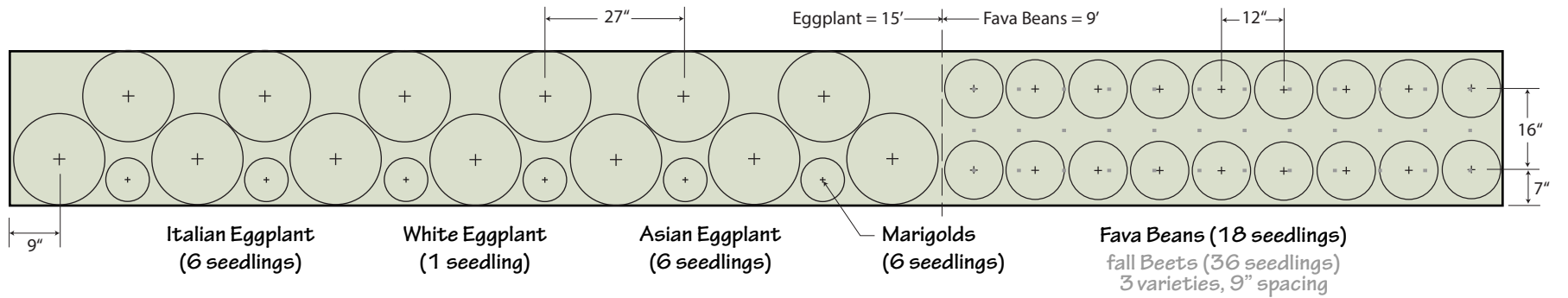

### WINTER SQUASH BED

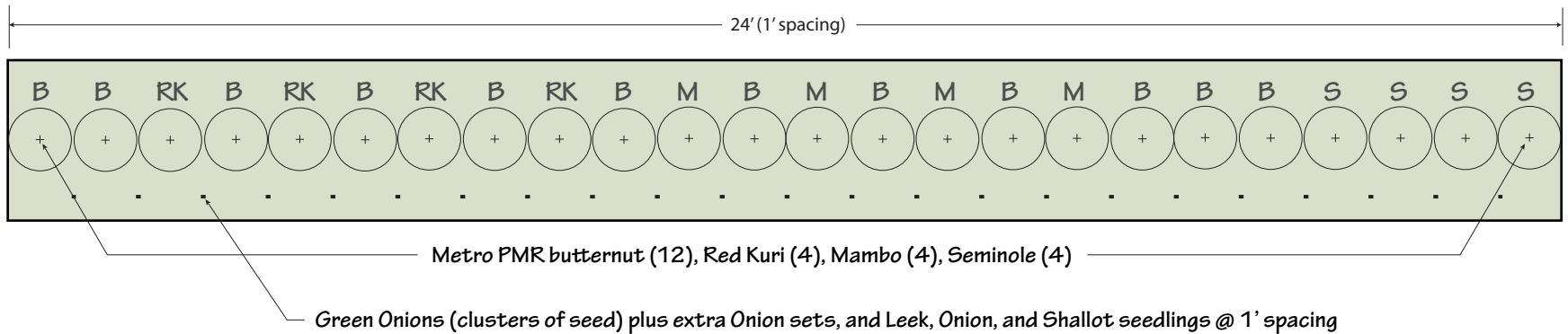

# CRESCENT, HERB & RAISED BEDS

